

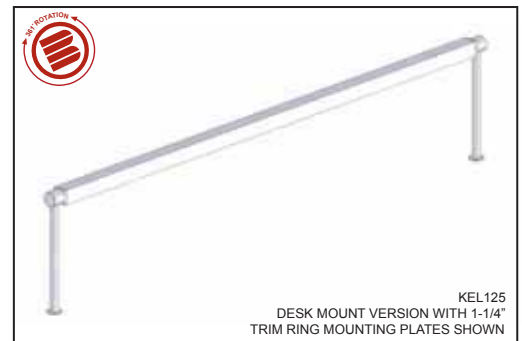

RAS MOUNTING OPTIONS

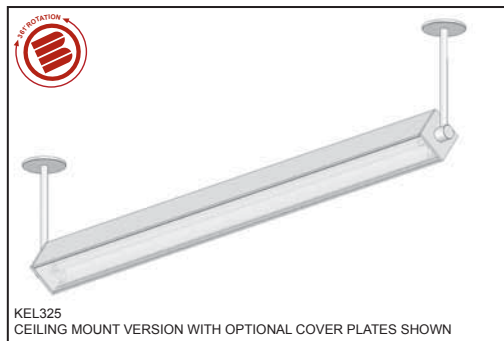
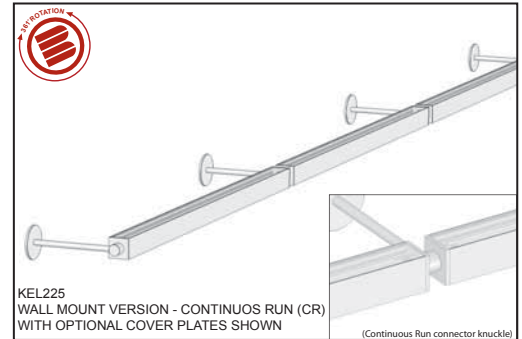
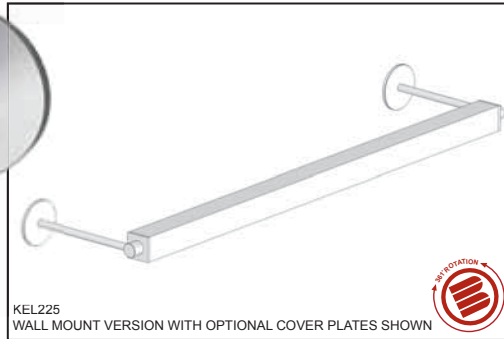

RAS MOUNTING SYSTEM

ROTATING ARM SYSTEM

DIRECT, INDIRECT, WALL WASH

- 361° rotation with positive stop
- 1/4" thick precision machined aluminum end caps
- 1-1/4" diameter precision machined aluminum knuckles
- 3-3/4" cover plate with no visible hardware for clean finished look
- 5/8" dia. aluminum arms in standard and custom lengths
- mounting and cover plates are available in several standard sizes and finishes - custom shapes are available consult factory
- various standard and custom finishes available
- single fixture and continuous run applications
- add "RAS" under the "Mounting" section of the base fixture

FIXTURE TO KNUCKLE PROPORTIONS



RAS

Mounting
RAS - Rotating Arm System

Fixture
KEL125- 1.25"
Size fixture
KEL225- 2.25"
Size fixture
KEL325- 3.25"
Size fixture

Arm Length**
6 - 6"
9 - 9"
12 - 12"
18 - 18****
CU - Custom*

*Specify length in inches - Consult factory for lengths over 18"

**Length is measured from mounting surface to the knuckle center

***Consult factory for use with KEL325

Mounting Plate
NMP - No Mounting Plate**
3OMP - 3-O J-Box Mounting Plate - (Galvanized Steel)
CMP - Custom Mounting Plate*

**Not recommended for wall mount applications

Cover Plate**
NCP - No Cover Plate
1TR - 1-1/4" Trim Ring
4CP - 4" Round Cover Plate
CCP - Custom Cover Plate*

**Optional - Used for clean, finished look

End Cap / Arm Knuckle Anodized Finish
MF - Match Fixture
BC - Bright Clear
FB - Flat Black
RM - Raw Machined
CU - Custom*

Options
225K - 2.25" diameter Knuckle
325K - 3.25" diameter Knuckle
Other - Specify

*Consult factory for all Custom (CU) options

Job Information

Type:

Job Name:

Location:

0309

BIRCHWOOD LIGHTING

714.550.7118 • fax 714.550.7151 • www.BirchwoodLighting.com

NOTE: Specifications and dimensions are subject to change without notice.





MOUNTING PLATE OPTIONS

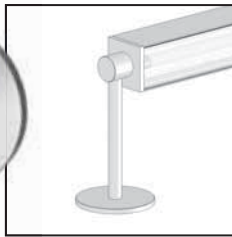

4CP: 4" Cover Plate: recommended for all mounting applications - Used for clean, finished look - No visible mounting hardware

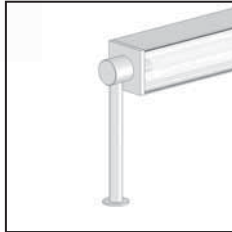

1TR: 1-1/4" Trim Ring: for use in applications where there is access behind mounting surface - recommended in lieu of the "NCP" option where the surface integrity is not as sound

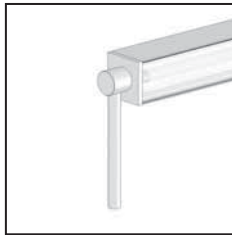

NCP: No Cover Plate: for use in applications where there is access behind mounting surface - surface should be relatively hard

KNUCKLE AND ARM DETAILS

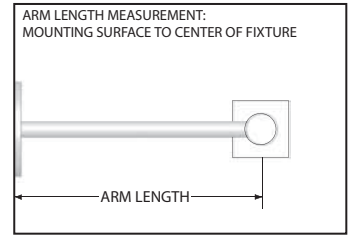
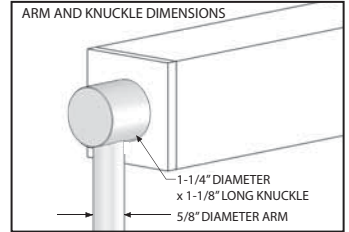
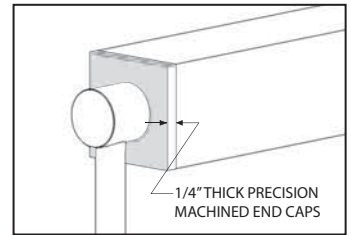

RAS MOUNTING SYSTEM

ROTATING ARM SYSTEM

DIRECT, INDIRECT, WALL WASH

- 361° rotation with positive stop
- 1/4" thick precision machined aluminum end caps
- 1-1/4" diameter precision machined aluminum knuckles
- 3-3/4" cover plate with no visible hardware for clean finished look
- 5/8" dia. aluminum arms in standard and custom lengths
- mounting and cover plates are available in several standard sizes and finishes - custom shapes are available consult factory
- various standard and custom finishes available
- single fixture and continuous run applications
- add "RAS" under the "Mounting" section of the base fixture

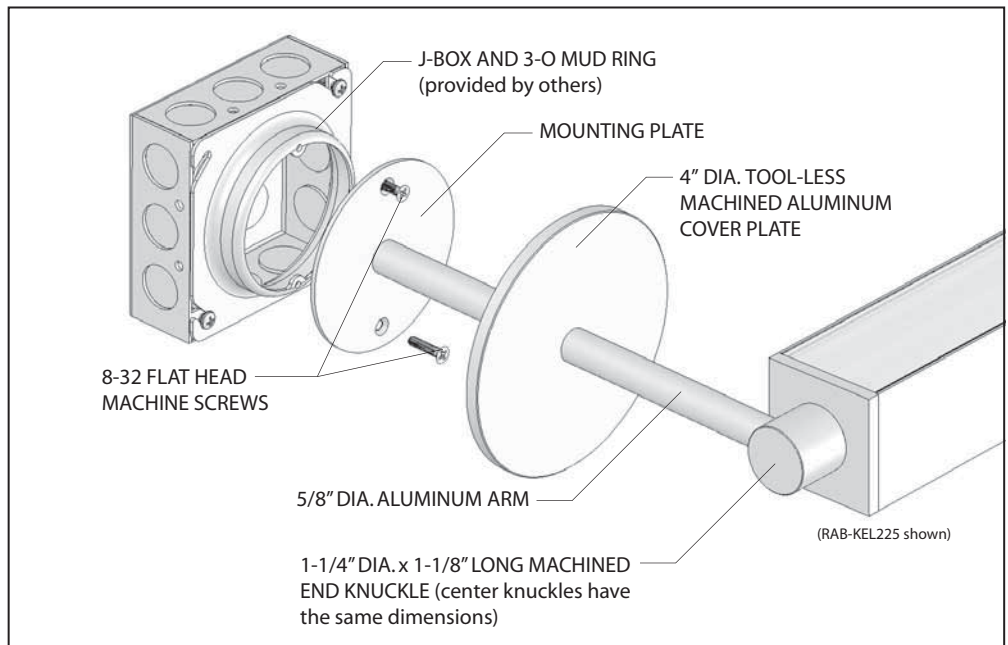

Job Information

Type: _____

Job Name: _____

Location: _____

0309

BIRCHWOOD LIGHTING

714.550.7118 • fax 714.550.7151 • www.BirchwoodLighting.com

NOTE: Specifications and dimensions are subject to change without notice.



kelsey - RAS

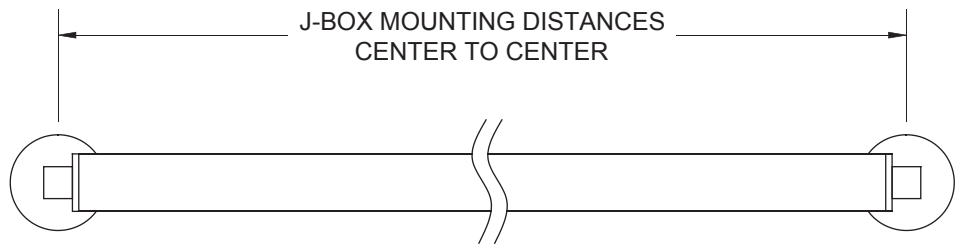
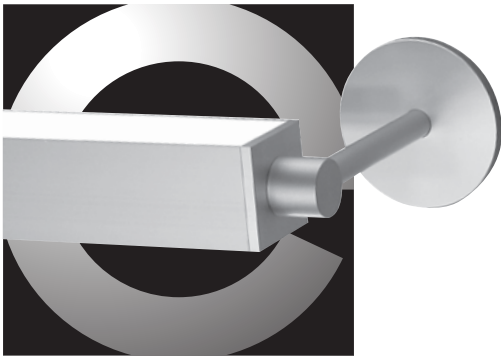

MOUNTING CENTERS*

INDIVIDUAL AND CONTINUOUS RUN APPLICATIONS

*CUSTOM FIXTURE LENGTHS AND MOUNTING CENTERS ARE AVAILABLE - CONTACT FACTORY

RAS MOUNTING SYSTEM

CENTER TO CENTER MOUNTING DISTANCES

CONTINUOUS RUN WORKSHEET

T5/T5HO

Nominal Fixture Length	2'	3'	4'	5'	6'	8'
Mounting Centers	24-3/8"	36-1/4"	48"	60"	70-1/2"	94-1/8"

T8

Nominal Fixture Length	2'	3'	4'	5'	6'	8'
Mounting Centers	26"	38"	50"	62"	74"	98"

CONTINUOUS RUN WORKSHEET

FOR ALL CONTINUOUS RUN APPLICATIONS, PLEASE USE THE FOLLOWING WORKSHEET

OPTION 1

BASIC RUN - SPECIFY THE RUN/TYPE AND RUN LENGTH - UNDER "FIXTURE LENGTHS" SPECIFY THE FIXTURE QUANTITY AND CORRESPONDING FIXTURE SEGMENT LENGTHS TO COMPOSE THE RUN

OPTION 2

RUN SPECIFIC - SPECIFY THE RUN/TYPE, RUN LENGTH, THE CORRESPONDING FIXTURES, AND THEIR RESPECTIVE LOCATION IN THE RUN (USED FOR MORE COMPLEX RUN CONFIGURATIONS) - USE ADDITIONAL LINES OR SHEETS FOR LONG RUNS AS NECESSARY

RUN/ TYPE RUN LENGTH FIXTURE LENGTHS

F1 24' (6) 4' Fixtures OPTION 1 EXAMPLE

F2 26' 3' 4' 4' 4' 4' 4' 3' OPTION 2 EXAMPLE

NOTES

- 1) 325 SERIES: 4', 6', AND 8' WALL MOUNTED RAS FIXTURES (INDIVIDUAL OR CONTINUOUS RUN SEGMENTS) SHOULD NOT BE USED WITH ARMS LONGER THAN 12", 9", AND 6" RESPECTIVELY WITHOUT ADDITIONAL SUPPORT - CONSULT FACTORY
- 2) 225 SERIES: 6' AND 8' WALL MOUNTED RAS FIXTURES (INDIVIDUAL OR CONTINUOUS RUN SEGMENTS) SHOULD NOT BE USED WITH ARMS LONGER THAN 15" AND 12" RESPECTIVELY WITHOUT ADDITIONAL SUPPORT - CONSULT FACTORY
- 3) 125 SERIES: 6' AND 8' WALL MOUNTED RAS FIXTURES MAY EXPERIENCE MINOR FATIGUE WITH 18" ARMS - SEE WIRING DIAGRAM PAGE FOR MORE NOTES
- 4) PLEASE CONSULT FACTORY FOR APPLICATION ASSISTANCE

Job Information

Type: _____

Job Name: _____

Location: _____

BIRCHWOOD LIGHTING

714.550.7118 • fax 714.550.7151 • www.BirchwoodLighting.com

NOTE: Specifications and dimensions are subject to change without notice. - consult factory to confirm all measurements

