

## kelsey - 325

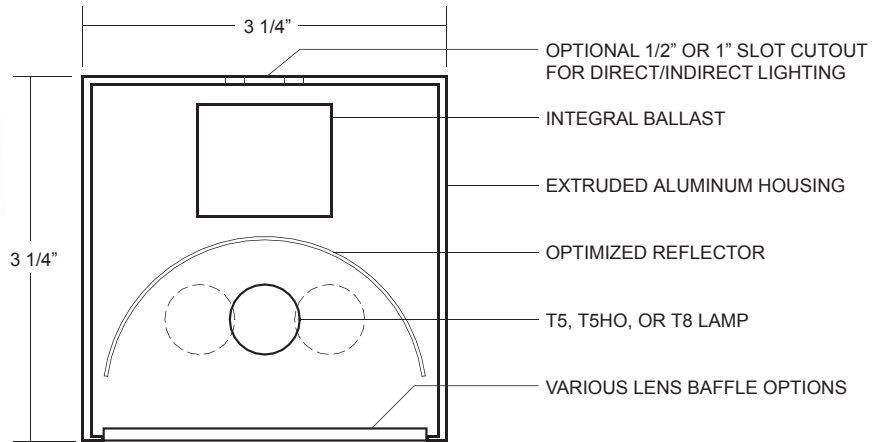
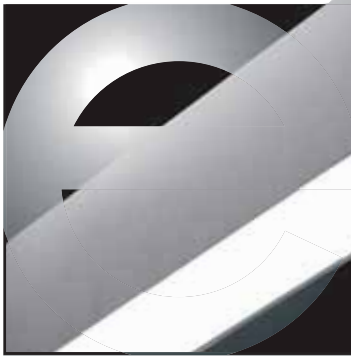

### MOUNTING OPTIONS

#### 3.25" SQUARE FIXTURE

#### MULTIPLE FIXTURE MOUNTING OPTIONS

DIRECT, INDIRECT, WALL WASH, ROTATIONAL STACK LIGHTING

- 3-1/4" square extruded aluminum housing
- 1/4" thick precision machined aluminum end caps
- extruded aluminum high efficacy polished reflector (T5 and T5HO)
- 80% fixture efficacy (no lens)
- rotating arm bracket, cable suspended, rotating cable suspended, stack mounting options
- 36° rotation with positive stop on rotating versions
- variety of lensing options
- satin anodized clear finish is standard - a variety of other standard and custom finishes are available
- T5, T5HO, and T8 linear fluorescent lamp types
- integral electronic ballasts are standard. consult Options p5 for available types of dimming and emergency ballasts
- UL and C-UL listed for Dry and Damp locations

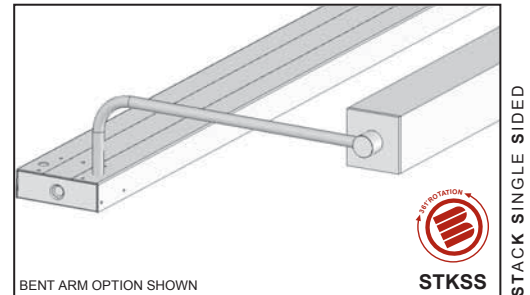
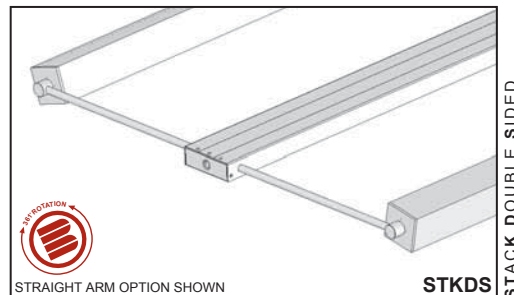
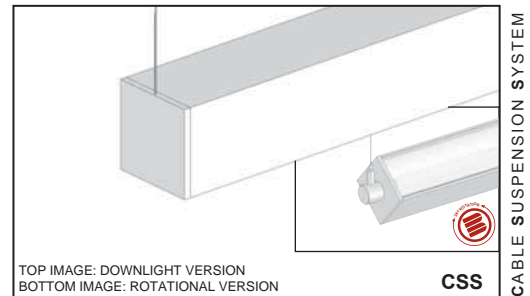
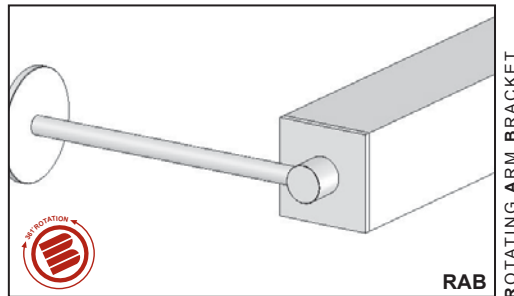

KEL	325												
Series KEL - Kelsey	Model 325	Mounting*	Lamp Qty.	Lamp	Nominal Length	Voltage	Ballast	Finish	Options*	Lens			
		RAB - Rotating Arm Bracket CSS - Cable Suspension System STKSS - Single Sided Stack System STKDS - Double Sided Stack System SM - (surface mount)	1 2	T5 T5HO T8	2 - 2' 3 - 3' 4 - 4' 5 - 5' 6 - 6' 8 - 8' CU - Custom* CR - ** - Continuous Run*	1 - 120V 2 - 277V 3 - 347V	EB - electronic DIM__ - dimming* EM__ - emergency*	SC - Satin Clear BC - Bright Clear FB - Flat Black CU - Custom*	.5S - 1/2" Slot 1S - 1" Slot *Consult factory for these and other options	NL - No Lens SIC - Satin Ice Clear SIW - Satin Ice White LP - Linear Prismatic** CU - Custom*			
		*ALL mounting options require further specification - See following pages				*Refer to Options p5 for DIM__ and EM__ option codes		*Consult Factory		*Consult Factory **Non-stocked item - longer lead time			
						*Consult Factory **Specify length in nominal feet							

#### Job Information

Type: \_\_\_\_\_

Job Name: \_\_\_\_\_

Location: \_\_\_\_\_

0309

## BIRCHWOOD LIGHTING

714.550.7118 • fax 714.550.7151 • www.BirchwoodLighting.com

NOTE: Specifications and dimensions are subject to change without notice.





### CSS OPTIONS

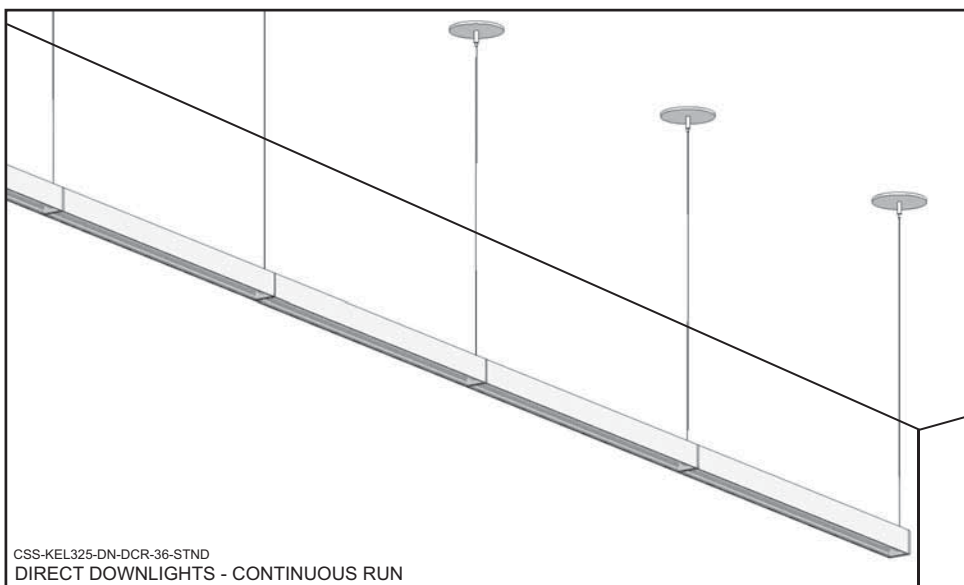

CSS-KEL325-DN-DCR-36-STND  
DIRECT DOWNLIGHTS - CONTINUOUS RUN

### CSS

#### CABLE SUSPENSION SYSTEM

DIRECT, INDIRECT, WALL WASH, ROTATIONAL

- 1/4" thick precision machined aluminum end caps
- rotational - wall wash - version rotates 36° with positive stop
- standard canopy mounting options - custom shapes, sizes and finishes available - consult factory
- can be installed without a canopy
- standard 1/16" diameter stainless steel cable. Consult factory for other cable diameters
- cables come in standard lengths and are field adjustable - consult factory for other options
- power cords available in white, black, gray, and braided - consult factory for other options
- add "CSS" under "Mounting" section

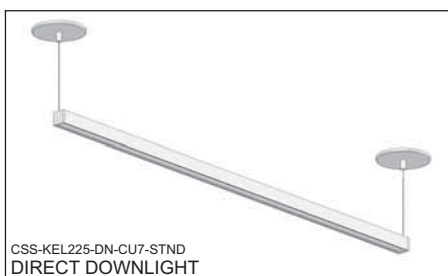

CSS-KEL225-DN-CU7-STND  
DIRECT DOWNLIGHT

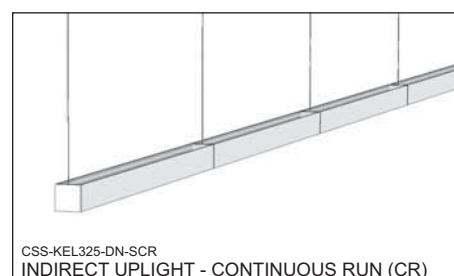

CSS-KEL325-DN-SCR  
INDIRECT UPLIGHT - CONTINUOUS RUN (CR)

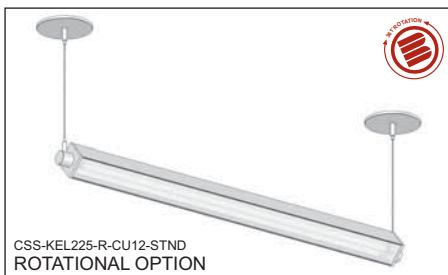

CSS-KEL225-R-CU12-STND  
ROTATIONAL OPTION

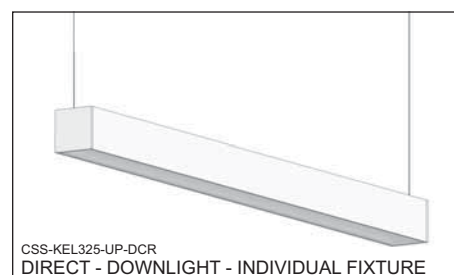

CSS-KEL325-UP-DCR  
DIRECT - DOWNLIGHT - INDIVIDUAL FIXTURE

### CSS

**Mounting**  
CSS - Cable Suspended System

**Fixture**  
KEL125 - 1.25" Diameter fixture  
KEL225 - 2.25" Diameter fixture  
KEL 325 - 3.25" Diameter fixture

**Orientation**  
UP - Uplight  
DN - Downlight  
R - Rotational

**Continuous Run Option\*\***  
SCR - Seamless Continuous Run  
DCR - Disc Continuous Run  
RCR - Rotational Continuous Run

\*\*For individual fixtures, leave blank

**Cable Length**  
36 - 36"  
72 - 72"  
96 - 96"  
CU - Custom\* (Specify length in inches - ie: CU148)

**Mounting Options**  
STND - Bracket bar w/5" round Canopy  
NC - No Canopy - 1/4-20 Side Exit Cable Gripper - (1/4-20 stud provided by others)  
CU - Custom\*

**Canopy Finish (Powder Coat)**  
MW - Matte White  
HRW - High Reflectance White  
SL - Silver  
FB - Flat Black  
CU - Custom\*

**Power Cord Color**  
W - White  
B - Black  
G - Gray  
SC - Braided Cable  
CU - Custom\*

**End Cap / Disc / Arm / Knuckle: Anodized Finish**  
MF - Match Fixture  
SC - Satin Clear  
BC - Bright Clear  
FB - Flat Black  
RM - Raw Machined  
CU - Custom\*

\*Consult factory for all Custom (CU) options

### Job Information

Type: \_\_\_\_\_

Job Name: \_\_\_\_\_

Location: \_\_\_\_\_

0309

## BIRCHWOOD LIGHTING

714.550.7118 • fax 714.550.7151 • www.BirchwoodLighting.com

NOTE: Specifications and dimensions are subject to change without notice.



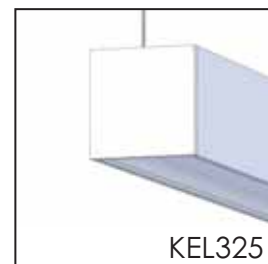
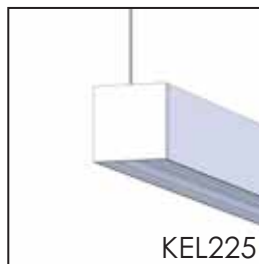

## CSS INSTALLATION INFORMATION

### CSS

#### CABLE SUSPENSION SYSTEM

DIRECT, INDIRECT, WALL WASH, ROTATIONAL

- 1/4" thick precision machined aluminum end caps
- rotational - wall wash - version rotates 36 1° with positive stop
- standard canopy mounting options - custom shapes, sizes and finishes available - consult factory
- can be installed without a canopy
- standard 1/16" diameter stainless steel cable. Consult factory for other cable diameters
- cables come in standard lengths and are field adjustable - consult factory for other options
- power cords available in white, black, gray, and braided - consult factory for other options
- add "CSS" under "Mounting" section

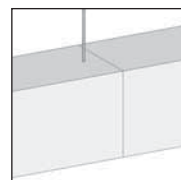
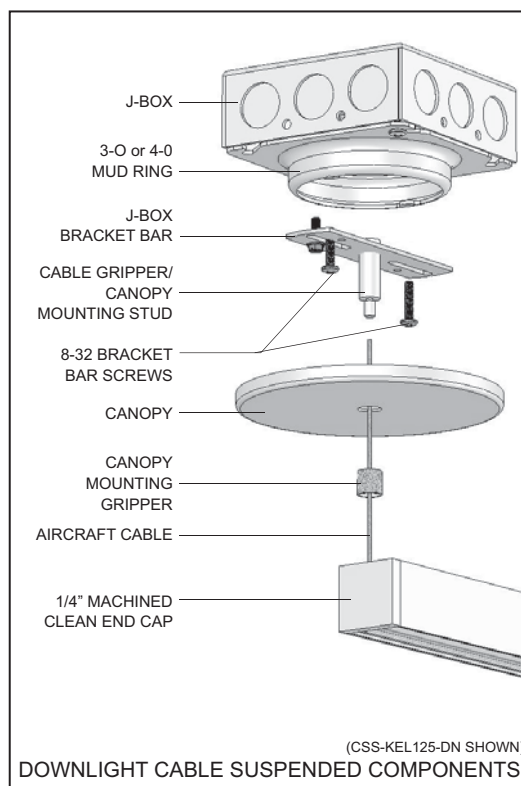
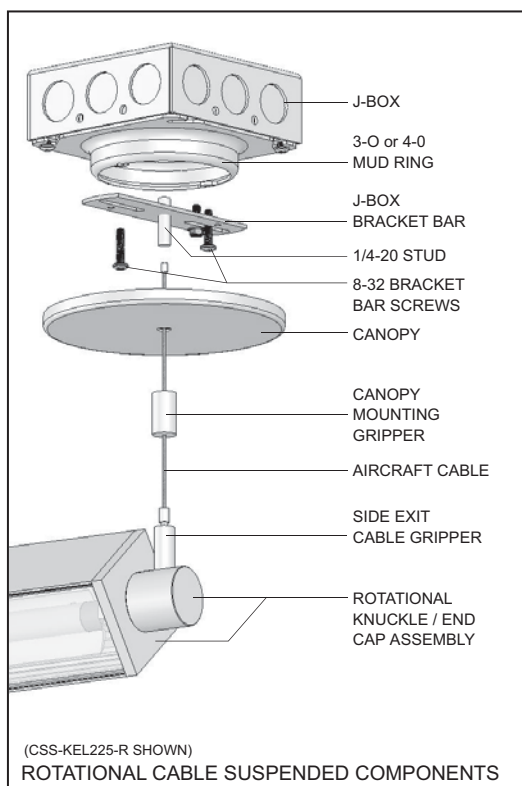

### Job Information

Type: \_\_\_\_\_

Job Name: \_\_\_\_\_

Location: \_\_\_\_\_

## BIRCHWOOD LIGHTING

714.550.7118 • fax 714.550.7151 • www.BirchwoodLighting.com

NOTE: Specifications and dimensions are subject to change without notice.



kelsey - CSS

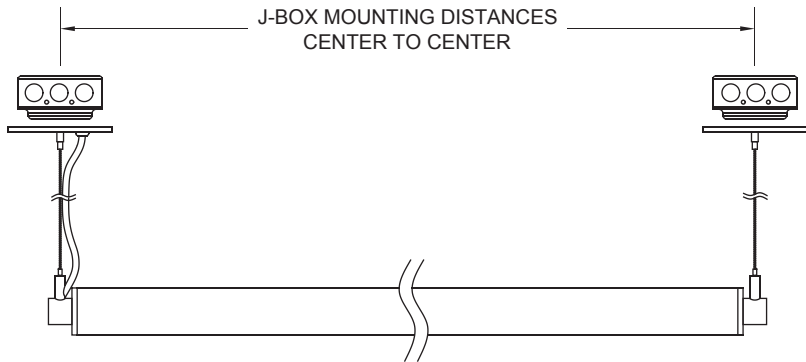

**MOUNTING CENTERS\***

INDIVIDUAL AND CONTINUOUS RUN APPLICATIONS

\*CUSTOM FIXTURE LENGTHS AND MOUNTING CENTERS ARE AVAILABLE - CONTACT FACTORY

**T5/T5HO**

Nominal Fixture Length	2'	3'	4'	5'	6'	8'
<b>Mounting Centers</b>	<b>24-3/8"</b>	<b>36-1/4"</b>	<b>48"</b>	<b>60"</b>	<b>70-1/2"</b>	<b>94-1/8"</b>

**T8**

Nominal Fixture Length	2'	3'	4'	5'	6'	8'
<b>Mounting Centers</b>	<b>26"</b>	<b>38"</b>	<b>50"</b>	<b>62"</b>	<b>74"</b>	<b>98"</b>

CSS MOUNTING SYSTEM  
ROTATIONAL VERSION

CENTER TO CENTER  
MOUNTING DISTANCES

CONTINUOUS RUN  
WORKSHEET

**CONTINUOUS RUN WORKSHEET**

FOR ALL CONTINUOUS RUN APPLICATIONS, PLEASE USE THE FOLLOWING WORKSHEET

**OPTION 1**

BASIC RUN - SPECIFY THE RUN/TYPE AND RUN LENGTH - UNDER "FIXTURE LENGTHS" SPECIFY THE FIXTURE QUANTITY AND CORRESPONDING FIXTURE SEGMENT LENGTHS TO COMPOSE THE RUN

**OPTION 2**

RUN SPECIFIC - SPECIFY THE RUN/TYPE, RUN LENGTH, THE CORRESPONDING FIXTURES, AND THEIR RESPECTIVE LOCATION IN THE RUN (USED FOR MORE COMPLEX RUN CONFIGURATIONS) - USE ADDITIONAL LINES OR SHEETS FOR LONG RUNS AS NECESSARY

RUN/ TYPE	RUN LENGTH	FIXTURE LENGTHS

F1	24'	(6) 4' Fixtures	OPTION 1 EXAMPLE
----	-----	-----------------	------------------

F2	26'	3' 4' 4' 4' 4' 4' 3'	OPTION 2 EXAMPLE
----	-----	----------------------	------------------

**NOTES**

- 1) 325 SERIES:
- 2) 225 SERIES:
- 3) 125 SERIES: SEE WIRING DIAGRAM PAGE FOR MORE NOTES
- 4) PLEASE CONSULT FACTORY FOR APPLICATION ASSISTANCE

**Job Information**

Type: \_\_\_\_\_

Job Name: \_\_\_\_\_

Location: \_\_\_\_\_

**BIRCHWOOD LIGHTING**

714.550.7118 • fax 714.550.7151 • www.BirchwoodLighting.com

NOTE: Specifications and dimensions are subject to change without notice. - consult factory to confirm all measurements



kelsey - lenses



KELSEY 125

KELSEY 225

KELSEY 325

## LENS INFORMATION

LENSES

GENERAL INFORMATION

**Satin Ice Clear (SIC):** Frosted clear acrylic with a "sandblasted" textured finish and appearance. Provides impressive lamp image diffusion with good light transmission and a soft glow. Used in applications where aesthetics and fixture efficacy are of high importance.

**Satin Ice White (SIW):** Frosted white acrylic with a "sandblasted" textured finish and appearance. Provides excellent lamp image diffusion with medium light transmission and a very soft glow. Used when aesthetics are more important than fixture efficacy.

**Linear Prismatic (LP):** Clear acrylic with linear micro prisms (approximately .015 height). Combines adequate lamp image diffusion with very good light transmission. Used to maximize fixture efficacy while maintaining some lamp image diffusing properties

**Clear (CL):** Clear acrylic - Provides no lamp image diffusion - Excellent light transmission. Ideal for upright dust cover applications or to maximize efficiency while still utilizing a lens.

LENS TYPE	Material	Lamp Image Diffusion	Light Transmission
Satin Ice Clear (SIC)	"Clear" Frosted Acrylic	Good	Good
Satin Ice White (SIW)	"White" Frosted Acrylic	Excellent	Average
Linear Prismatic (LP)	Clear Acrylic	Average	Very Good
Clear (CL)	Clear Acrylic	Poor	Excellent

## NOTES

- 1) CONSULT FACTORY FOR MATERIAL SAFETY DATA SHEETS (MSDS) OR OTHER NECESSARY INFORMATION
- 2) SAMPLES AVAILABE UPON REQUEST

### Job Information

Type: \_\_\_\_\_

Job Name: \_\_\_\_\_

Location: \_\_\_\_\_

0309

## BIRCHWOOD LIGHTING

714.550.7118 • fax 714.550.7151 • [www.BirchwoodLighting.com](http://www.BirchwoodLighting.com)

NOTE: Specifications and dimensions are subject to change without notice. - consult factory to confirm all measurements



KEL - P13