

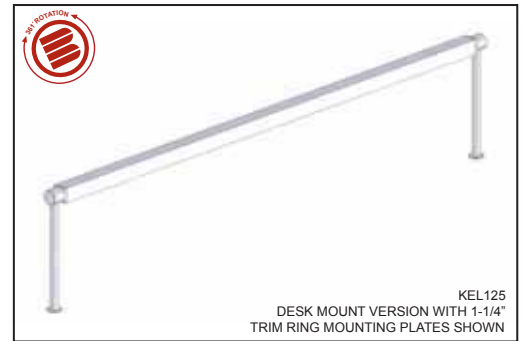

## RAS MOUNTING OPTIONS

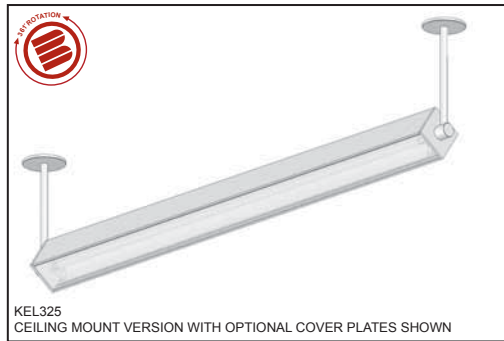
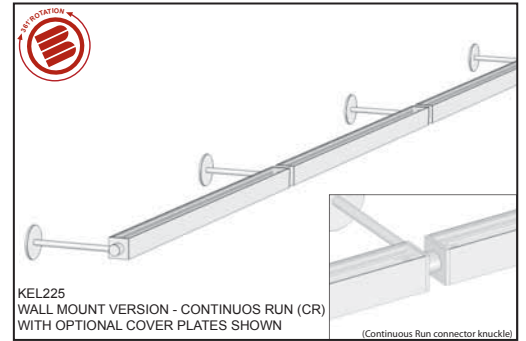
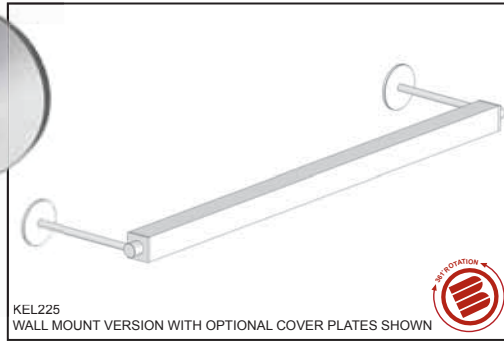

### RAS MOUNTING SYSTEM

#### ROTATING ARM SYSTEM

#### DIRECT, INDIRECT, WALL WASH

- 361° rotation with positive stop
- 1/4" thick precision machined aluminum end caps
- 1-1/4" diameter precision machined aluminum knuckles
- 3-3/4" cover plate with no visible hardware for clean finished look
- 5/8" dia. aluminum arms in standard and custom lengths
- mounting and cover plates are available in several standard sizes and finishes - custom shapes are available consult factory
- various standard and custom finishes available
- single fixture and continuous run applications
- add "RAS" under the "Mounting" section of the base fixture

## FIXTURE TO KNUCKLE PROPORTIONS

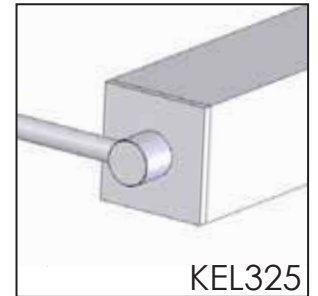
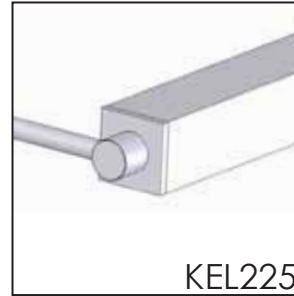

### RAS

**Mounting**  
RAS - Rotating Arm System

**Fixture**  
KEL125- 1.25"  
Size fixture  
KEL225- 2.25"  
Size fixture  
KEL325- 3.25"  
Size fixture

**Arm Length\*\***  
6 - 6"  
9 - 9"  
12 - 12"  
18 - 18\*\*\*\*  
CU - Custom\*

\*Specify length in inches - Consult factory for lengths over 18"

\*\*Length is measured from mounting surface to the knuckle center

\*\*\*Consult factory for use with KEL325

**Mounting Plate**  
NMP - No Mounting Plate\*\*  
3OMP - 3-O J-Box Mounting Plate - (Galvanized Steel)  
CMP - Custom Mounting Plate\*

\*\*Not recommended for wall mount applications

**Cover Plate\*\***  
NCP - No Cover Plate  
1TR - 1-1/4" Trim Ring  
4CP - 4" Round Cover Plate  
CCP - Custom Cover Plate\*

\*\*Optional - Used for clean, finished look

**End Cap / Arm Knuckle Anodized Finish**  
MF - Match Fixture  
BC - Bright Clear  
FB - Flat Black  
RM - Raw Machined  
CU - Custom\*

**Options**  
225K - 2.25" diameter Knuckle  
325K - 3.25" diameter Knuckle  
Other - Specify

\*Consult factory for all Custom (CU) options

### Job Information

Type: \_\_\_\_\_

Job Name: \_\_\_\_\_

Location: \_\_\_\_\_

0309

## BIRCHWOOD LIGHTING

714.550.7118 • fax 714.550.7151 • www.BirchwoodLighting.com

NOTE: Specifications and dimensions are subject to change without notice.

