

MOUNTING PLATE OPTIONS

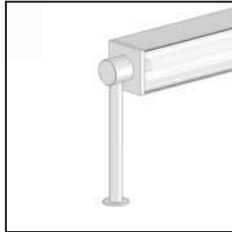

4CP: 4" Cover Plate: recommended for all mounting applications - Used for clean, finished look - No visible mounting hardware



1TR: 1-1/4" Trim Ring: for use in applications where there is access behind mounting surface - recommended in lieu of the "NCP" option where the surface integrity is not as sound

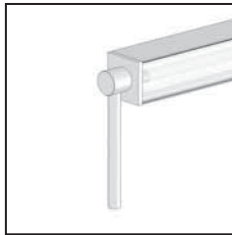

NCP: No Cover Plate: for use in applications where there is access behind mounting surface - surface should be relatively hard

KNUCKLE AND ARM DETAILS

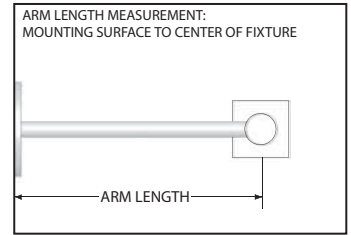
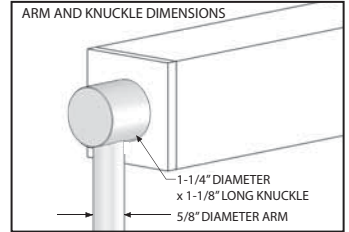
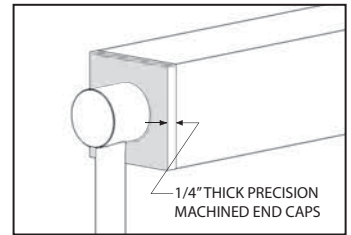

RAS MOUNTING SYSTEM

ROTATING ARM SYSTEM

DIRECT, INDIRECT, WALL WASH

- 361° rotation with positive stop
- 1/4" thick precision machined aluminum end caps
- 1-1/4" diameter precision machined aluminum knuckles
- 3-3/4" cover plate with no visible hardware for clean finished look
- 5/8" dia. aluminum arms in standard and custom lengths
- mounting and cover plates are available in several standard sizes and finishes - custom shapes are available consult factory
- various standard and custom finishes available
- single fixture and continuous run applications
- add "RAS" under the "Mounting" section of the base fixture

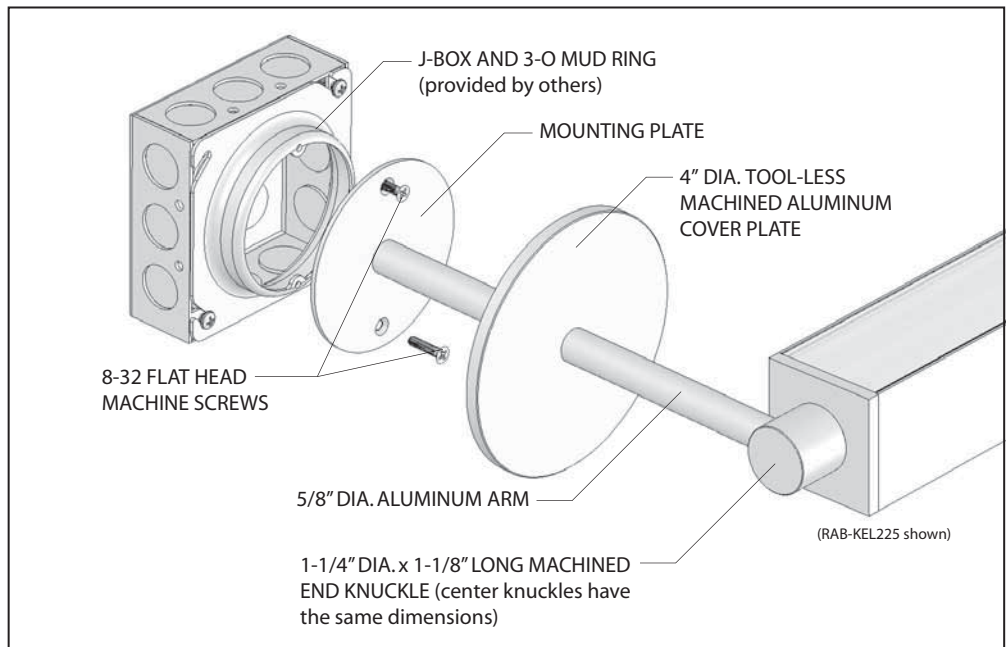

Job Information

Type: _____

Job Name: _____

Location: _____

0309

BIRCHWOOD LIGHTING

714.550.7118 • fax 714.550.7151 • www.BirchwoodLighting.com

NOTE: Specifications and dimensions are subject to change without notice.



KELp10