

SPECIALTY

ISC

DIRECT / INDIRECT LIGHT DISTRIBUTION

T8, T5 or T5HO

- 20 gauge steel construction
- uses T8, T5 or T5HO linear fluorescent lamps
- two-lamp cross section
- maximum 24-foot seamless length with 4-foot perforated pattern at each lamp
- end caps welded to body of housing
- standard ballasts are integral electronic, consult Options p5 for available types of dimming and emergency ballasts
- cable suspension system (CSS) refer to page-1 of "Options" section for more details
- standard finish is High Reflectivity White powder coat done post production, decorative Large Pattern Galvanize and other custom colors and finishes are also available
- UL and C-UL Listed for Dry and Damp Locations

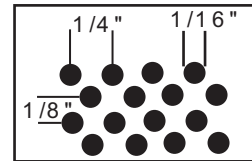
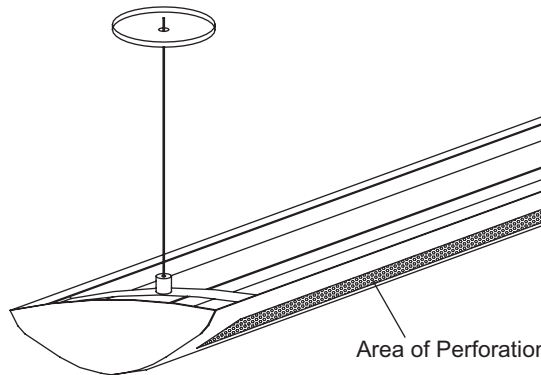
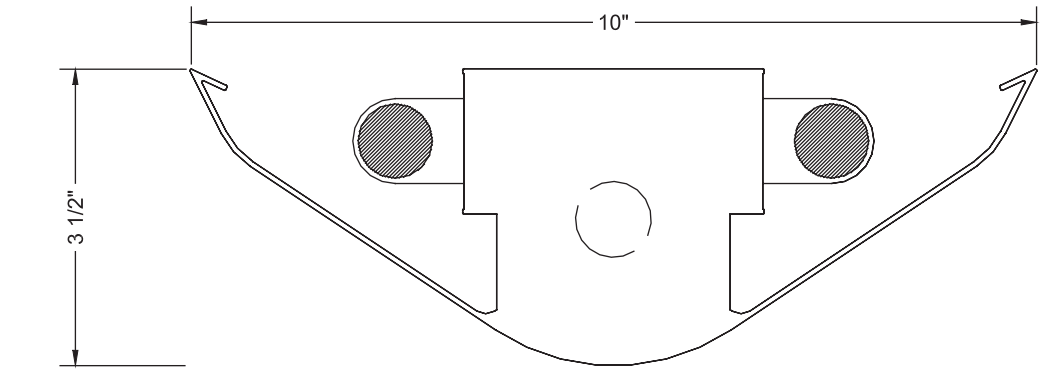

Pattern of Perforation

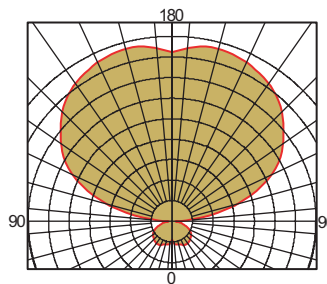

For a complete photometric report and IES file go to www.BirchwoodLighting.com or contact the factory

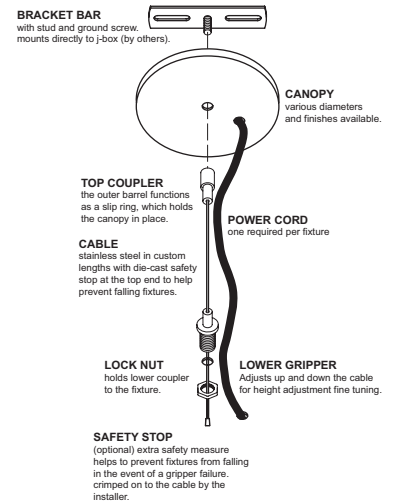

ISC

Model
ISC

Lamp Type
T8 - T8
T5 - Standard T5
T5HO - T5 High Output

Voltage
120
277
347

Ballast
EB - electronic
DIM__ - dimming*
EM__ - emergency*
*refer to Options p5 for DIM__ and EM__ options code

Length
4 - 4'
8 - 8'
12 - 12'
16 - 16'
24 - 24'
R__ - run length
runs are made up of 8' nominal sections unless otherwise specified

Options
Finish
HRW - High Reflectivity White
LPG - Large Pattern Galvanize
CU - Custom (please specify)

Job Information

Type

Job Name

Location

BIRCHWOOD LIGHTING

714.550.7118 • fax 714.550.7151 • www.BirchwoodLighting.com

NOTE: Specifications and dimensions are subject to change without notice.

